

## E200

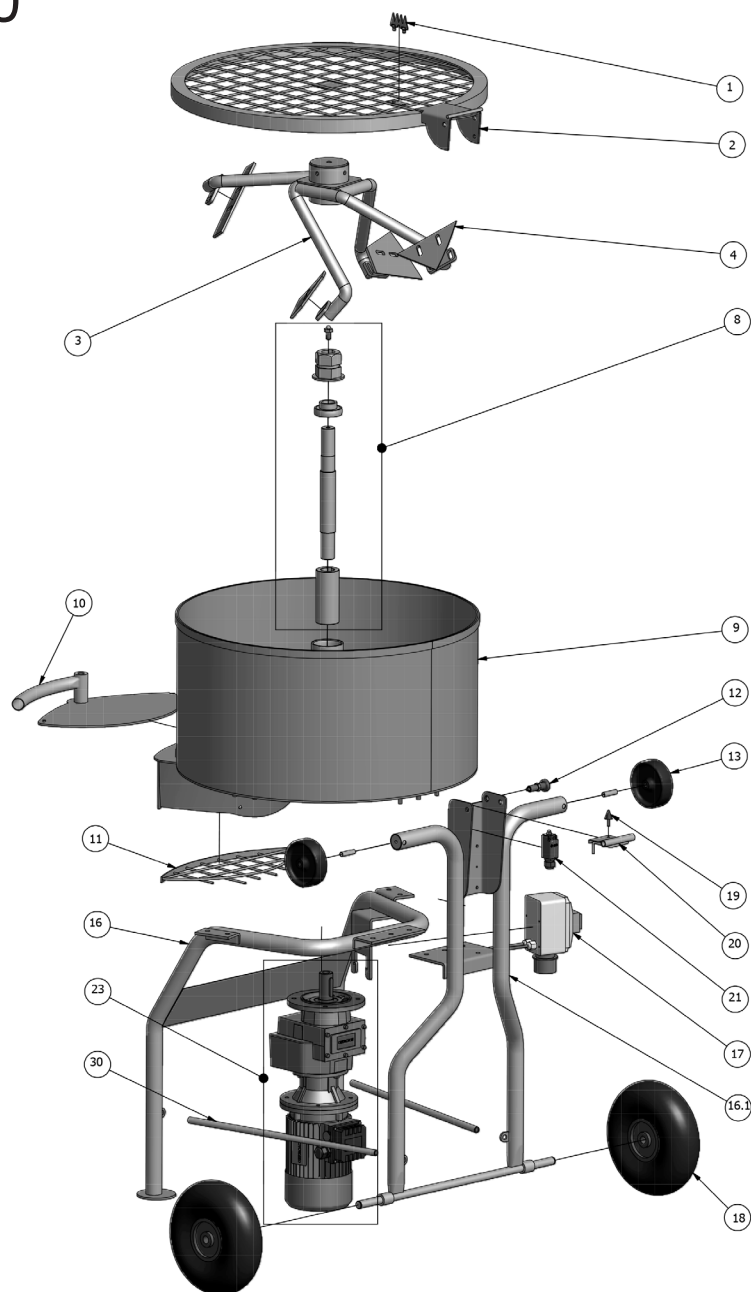

POS.	PART NO.	DESCRIPTION
1	50641	Sack knife, complete
2	50541	Cover
3	50426	Mixer head (without shovels)
4	50441	Metal shovels, complete set (4 pcs)
8	50652	Drive shaft, complete
9	50503	Container
10	50375	Trapdoor, complete
11	50351	Outlet protection
12	50328	Positioning bolt
13	50343	Transportwheel, complete (1 pc)
16	50529	Front frame
16,1	50530	Back frame
17	50302	Main switch, 380V
18	50340	Wheel, 20x75 (1 pc)
19	50327	Rubber damper
20	50601	Plate for cover switch
21	50326	Mechanical cover switch
23	50203	Motor + gear, 2.2kW 3x380V, Fabrika
30	50572	Connection bar (1 pc)

POS.	PART NO.	OTHER SPARE PARTS
	50621	Dust cover (lid)
	50628	Filling cap for dust cover
	50464	Rubber shovels, complete set (4 pcs)
	50224	Motor, 2.2kW 3x380V, Fabrika
	50223	Motor, 1.8kW 110V, Fabrika
	50231	Gear for E200/M200, Fabrika
	50206	Motor + gear, 2.2kW 3x380V, Motovario
	50305	Main switch, 110V 20-25A
	50324	E-stop lid for main switch
	30300	Rubber protection f/on-off
	50323	Emergency stop f/mixer yellow, old model
	50263	Main relais, 20-25A
	50270	Undervoltage relais, 110V
	50271	Undervoltage relais, 240V
	50272	Undervoltage relais, 380V
	50108	Extension cable, 3x380V CEE, 5m
	50106	Extension cable, 3x380V CEE, 10 m